

# StresCore Inc.

Producers of  
Corefloor

Prestressed Hollowcore Slab



UPDATED 2017

## A QUALITY SOLUTION WITH UNMATCHED VERSATILITY

StresCore hollowcore slabs provides a valuable solution to a large variety of projects. The hollowcore solution is an ideal fit for any project size, whether it be for a 500 square foot residential garage floor over a basement basketball court to a 100,000+ square foot multi-story apartment complex.

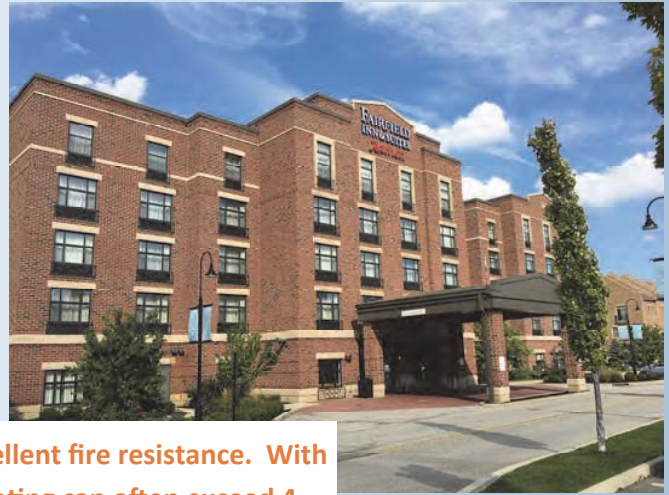

Hollowcore provides an excellent fire resistance. With proper detailing the fire rating can often exceed 4 hours. This superior fire resistance is an ideal fit for HOTELS, CONDOS AND APARTMENTS

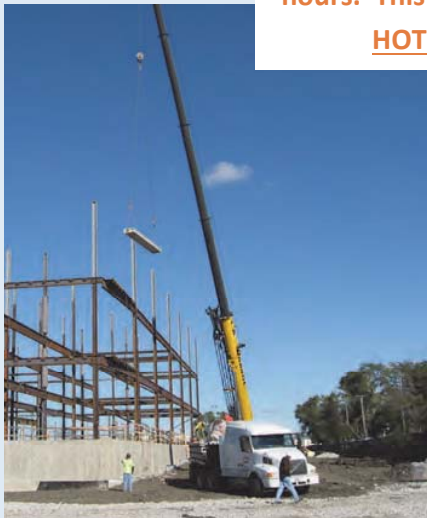

RESIDENTIAL HOME applications often include garage floors spanning basement home theaters and basketball courts. The long spans of hollowcore eliminate the extra columns and framing typical in basements and are capable of carrying garage vehicle loads.



Hollowcore is ideal for SCHOOL applications. StresCore has been successfully used for classrooms, gym floors and mezzanines. By providing a fire and sound resistant system, hollowcore is well suited for the classroom.

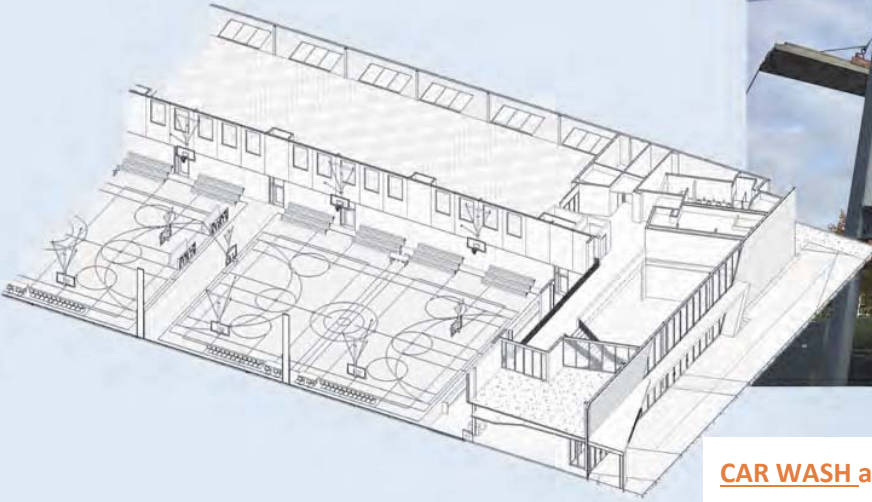

CAR WASH applications allows our clients to have the hollowcore rapidly manufactured and installed so that the business can be quickly opened. Mechanical equipment is easily hung from the underside of the hollowcore.

Hollowcore is well suited for WASTEWATER TREATMENT PLANTS because it provides a durable concrete solution in an abrasive environment while allowing equipment to be easily mounted to the slabs.



Prestressed hollowcore planks allow much longer spans with a lighter self weight and higher load carrying capacity. This is ideal for STADIUMS that demand long unobstructed spans with significant live loads.

**StresCore Inc.**

## FIRE RESISTANCE

Fire tests and other studies carried out by leading authorities have demonstrated the high performance characteristics of StresCore hollowcore slabs. Two hour fire ratings are achieved without an additional topping. The addition of a topping will produce ratings of three hours. Additional modifications to the hollowcore can lead to four hour ratings, which will satisfy even the most stringent code requirements.

### U.L. DESIGNS

- 6" - P.C.I. MNL-124
- 8" - J931, J932, J956
- 10" - J931, J932
- 12" - J931, J932

## THERMAL RESISTANCE PROPERTIES

Precast and prestressed concrete construction and the thermal inertia and thermal storage properties have an advantage over lightweight materials. The hollowcores also help to improve the thermal resistance of the system.

	6"	8"	10"	12"
R=	1.07	1.34	1.73	1.91



## LOW SOUND TRANSMISSION

Sound control is essential in building construction in order to ensure quiet buildings for pleasant living and working conditions. Sound transmission can be divided into two categories:

1. Impact Sound (foot steps)
2. Airborne Sound (voices or radio)

The density and the configuration of StresCore hollowcore combine to lend themselves extremely well to control of both impact and airborne sound transmission. Control of airborne sound in a room is readily accomplished by proper finishes. For effective control of impact sound transmission, installation of carpet finishes over hollowcore is desirable.

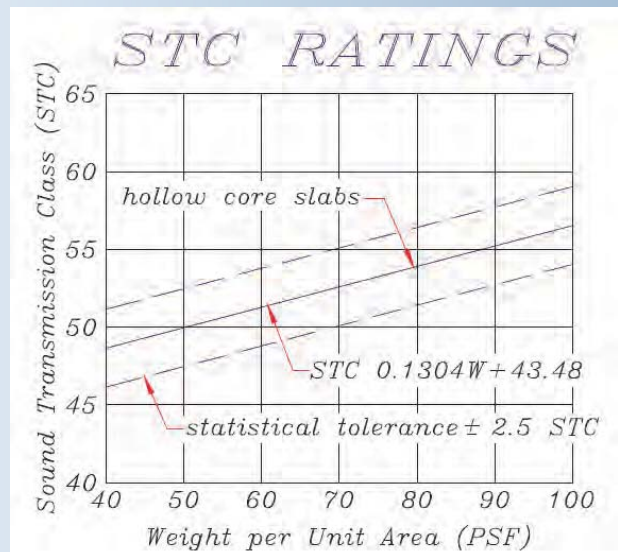

## FIRE RESISTANCE OF HOLLOWCORE

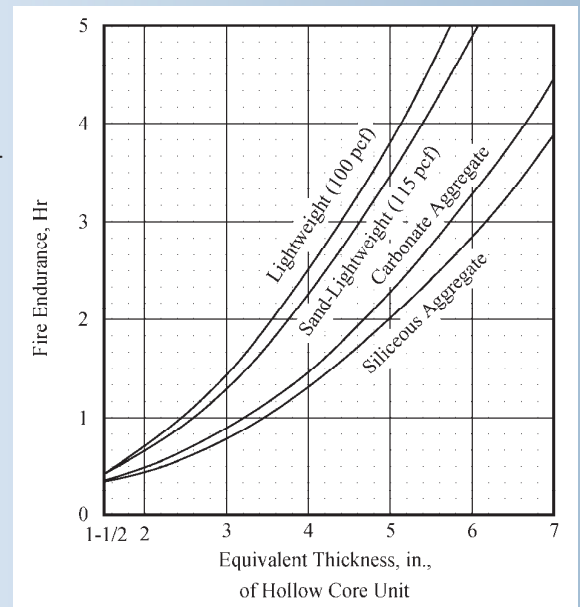

# StresCore Hollowcore Provides These Additional Advantages:

## ALL WEATHER CONSTRUCTION

StresCore hollowcore slabs are constructed indoors in a controlled environment. This means the slabs are constructed year round under any weather condition without sacrificing quality and always meeting construction tolerances. The slabs are precast, which are cured and cut to required lengths at the manufacturing plant where Quality Control can be most effectively exercised. The hollowcore slabs can be placed on the job under inclement weather conditions. With due precaution, grouting can be carried out even in low temperatures.



## WORK DECKS

Immediately after erection, a working surface is provided for other trades. Once the grout has been placed and set, the surface will be suitable for light duty construction equipment. The planks may potentially be suitable for larger vehicles and equipment, however coordination is required with StresCore on loading conditions. Under good conditions and proper scheduling, over 10,000 square feet of hollowcore have been placed in one day by a crew and a crane.

## ATTRACTIVE INTERIORS

The underside of a StresCore hollowcore slab has a smooth finish, resulting from the steel pallets uniform casting surface and close Quality Control during the manufacturing process. In buildings such as warehouses and garages, StresCore hollowcore ceilings present an attractive appearance just as they are. For commercial usage and residential dwellings, paint is the only finish required.

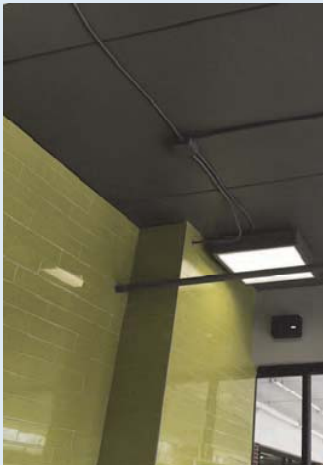

## 6" Non-Composite Load Table

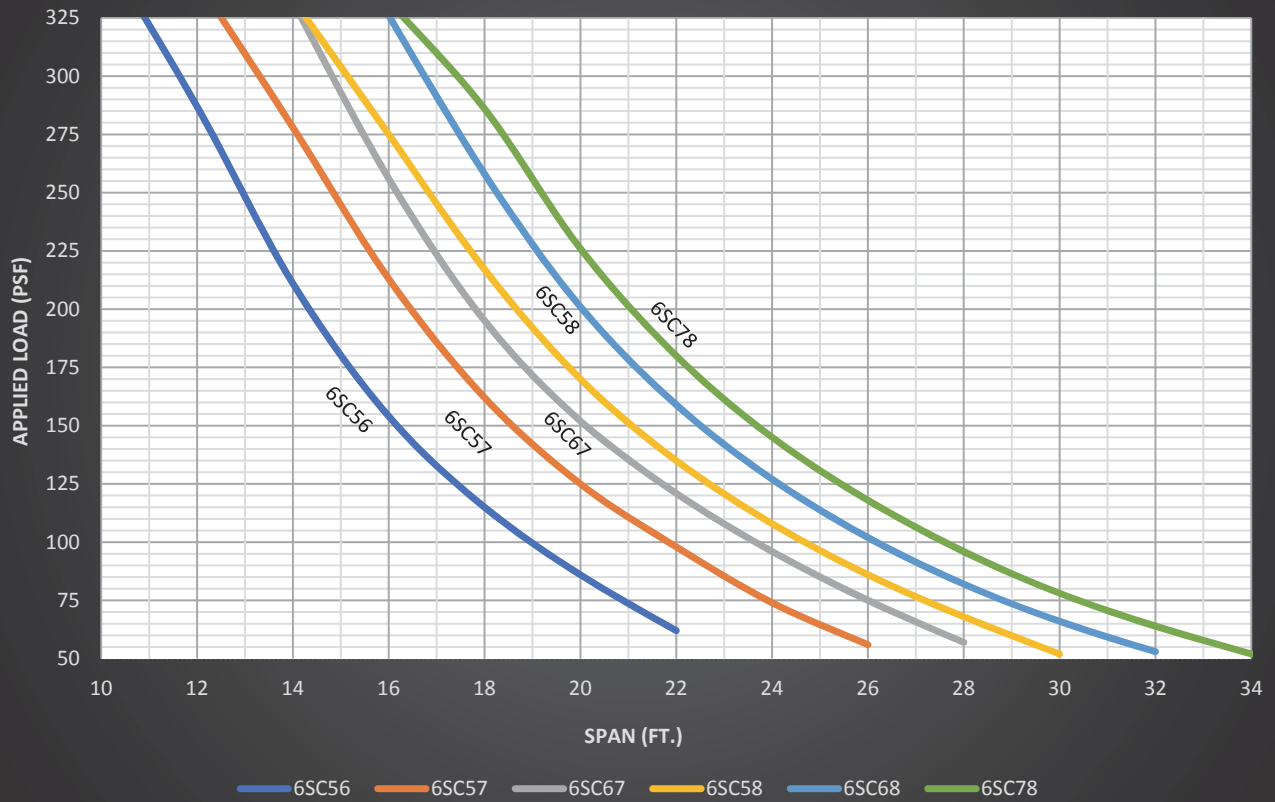

## 6" Composite Load Table

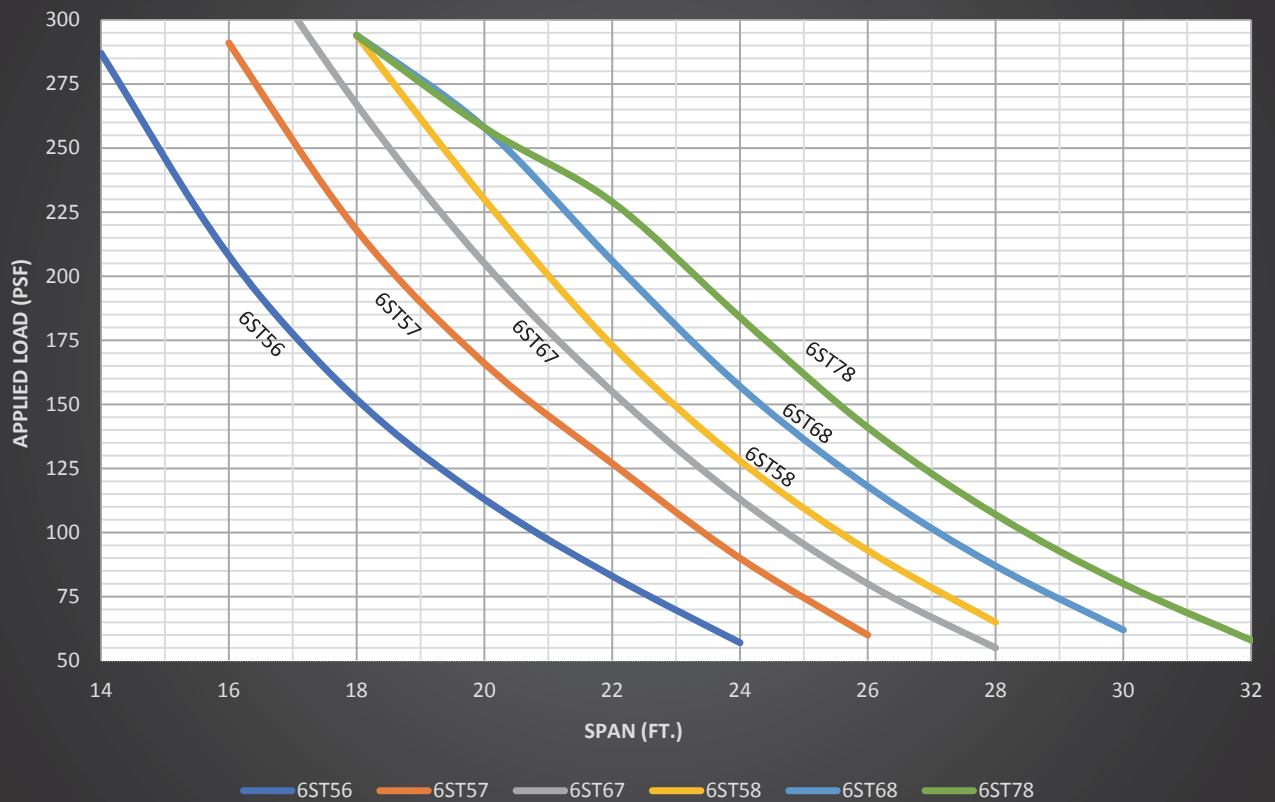

## 6" COREFLOOR FIGURES INDICATE SUPERIMPOSED LOADS

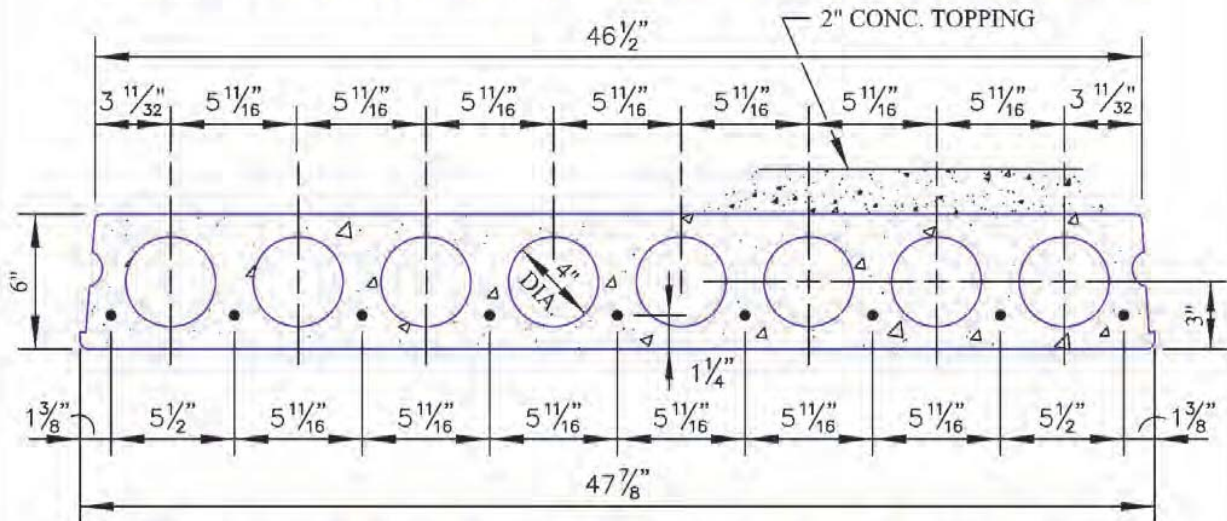

## SECTION PROPERTIES

### NON-COMPOSITE

$A = 188 \text{ IN.}^2$        $I = 764 \text{ IN.}^4$   
 $Y_b = 3.0 \text{ IN.}$        $WT = 49 \text{ PSF}$   
 $Y_t = 3.0 \text{ IN.}$

### COMPOSITE

$A = 284 \text{ IN.}^2$        $I = 1649 \text{ IN.}^4$   
 $Y_b = 4.14 \text{ IN.}$        $WT = 74 \text{ PSF}$   
 $Y_t = 3.86 \text{ IN.}$

## SPAN IN FEET

STRAND	10'	12'	14'	16'	18'	20'	22'	24'	26'	28'	30'	32'	34'
6SC56	356	287	211	154	115	86	62						
6SC57		341	278	213	162	125	98	74	56				
6SC67			332	256	195	152	121	96	75	57			
6SC58				333	275	217	170	135	108	86	68	52	
6SC68					326	258	201	159	127	102	82	66	53
6SC78					332	286	226	180	145	118	96	78	64
6ST56			287	208	152	113	83	57					
6ST57				291	218	166	127	90	60				
6ST67					267	205	155	113	80	55			
6ST58					294	230	173	128	93	65			
6ST68					294	258	206	157	118	87	62		
6ST78					294	258	229	184	141	107	80	58	

SUPERIMPOSED LOAD CAPACITY IN POUNDS PER SQUARE FOOT

\* IMMEDIATE & LONG TERM DEFLECTION MAY LIMIT APPLICATION

$f_{ci} = 3500 \text{ PSI} - 4000 \text{ PSI}$

$f_c = 6500 \text{ PSI}$

STRAND = 270 KSI L.R.

CONCRETE TOPPING = 4000 PSI

SC- UNTOPPED SECTION

ST- 2" COMPOSITE TOPPING

### 8" Non-Composite Load Table

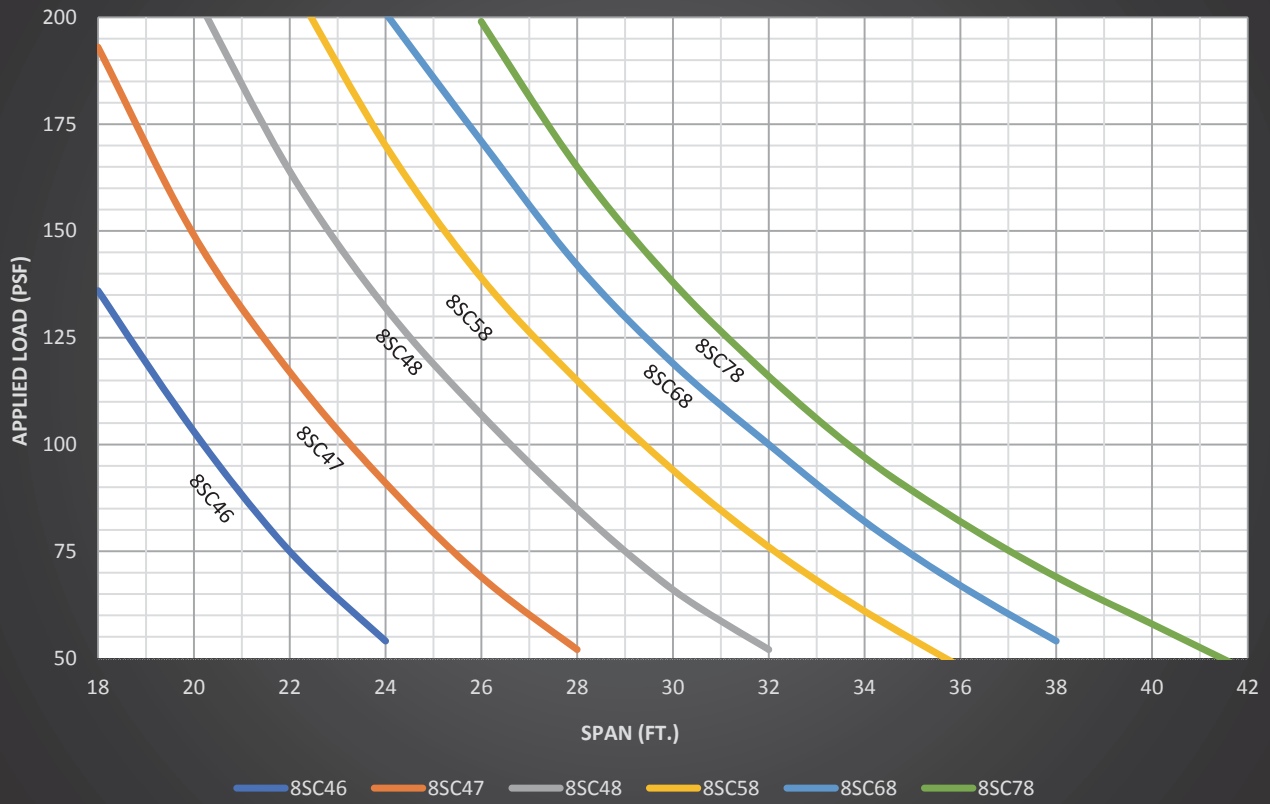

### 8" Composite Load Table

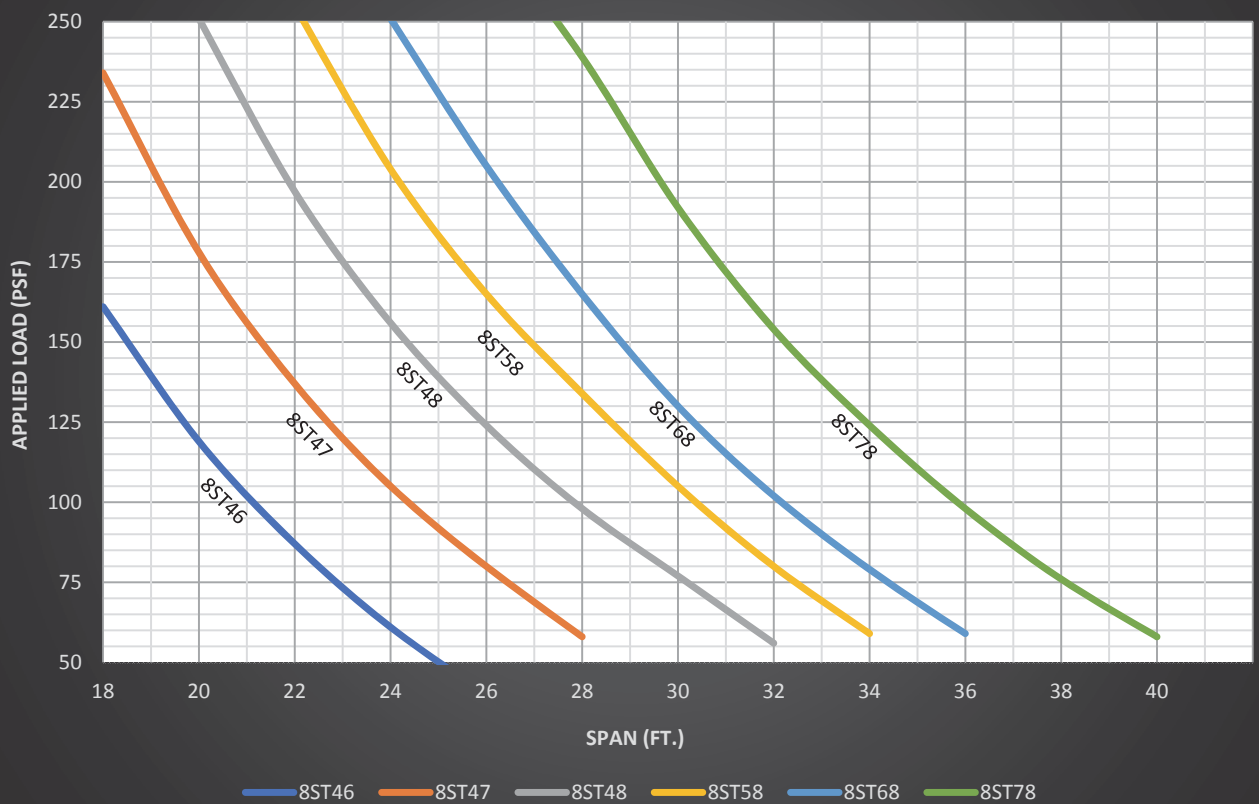



## 8" COREFLOOR FIGURES INDICATE SUPERIMPOSED LOADS

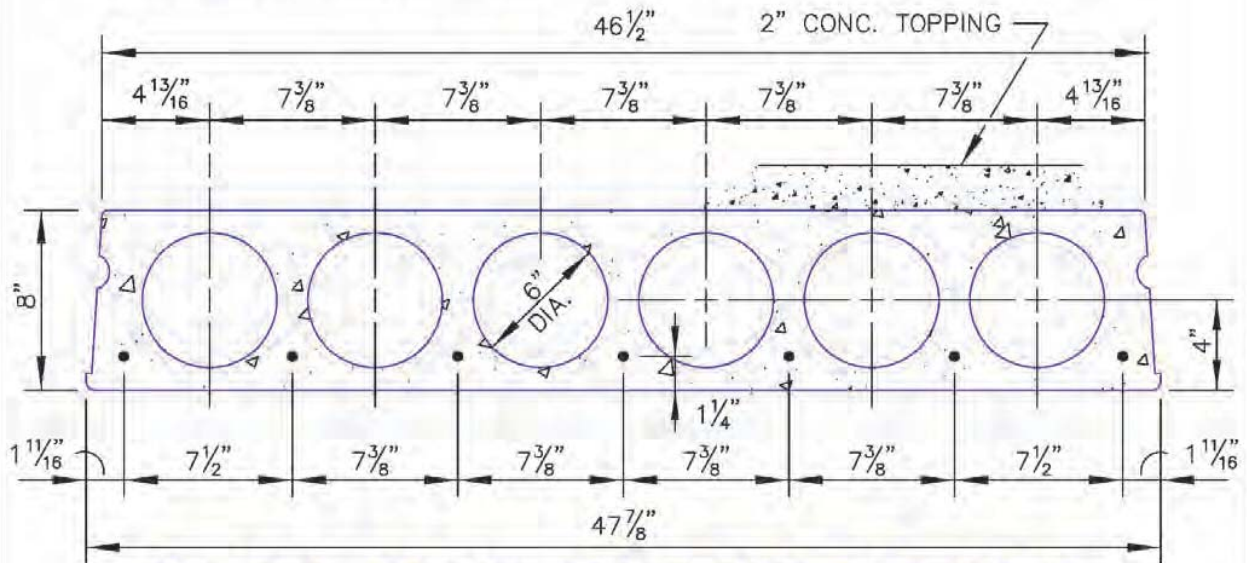

## SECTION PROPERTIES

### NON-COMPOSITE

$A = 214 \text{ in.}^2$        $I = 1666 \text{ in.}^4$   
 $Y_B = 4.0 \text{ in.}$        $WT = 56 \text{ PSF}$   
 $Y_T = 4.0 \text{ in.}$

### COMPOSITE

$A = 310 \text{ in.}^2$        $I = 3084 \text{ in.}^4$   
 $Y_B = 5.30 \text{ in.}$        $WT = 80 \text{ PSF}$   
 $Y_T = 4.70 \text{ in.}$

## SPAN IN FEET

STRAND	18'	20'	22'	24'	26'	28'	30'	32'	34'	36'	38'	40'	42'
8SC46	136	103	75	54									
8SC47	193	149	117	91	69	52							
8SC48		206	164	132	107	85	66	52					
8SC58			209	170	139	115	94	76	61	48			
8SC68				201	171	142	119	100	82	67	54		
8SC78					199	165	138	116	97	82	69	58	47
8ST46	161	119	87	61	40								
8ST47	234	178	137	105	80	58							
8ST48		251	197	156	124	98	77	56					
8ST58			255	204	165	134	105	80	59				
8ST68				251	205	165	130	102	79	59			
8ST78				279	239	192	154	124	98	76	58		

SUPERIMPOSED LOAD CAPACITY IN POUNDS PER SQUARE FOOT

\* IMMEDIATE & LONG TERM DEFLECTION MAY LIMIT APPLICATION

$f_{ci} = 3500 \text{ PSI} - 4000 \text{ PSI}$

CONCRETE TOPPING = 4000 PSI

$f_c = 6500 \text{ PSI}$

SC- UNTOPPED SECTION

STRAND = 270 KSI L.R.

ST- 2" COMPOSITE TOPPING

## 10" Non-Composite Load Table

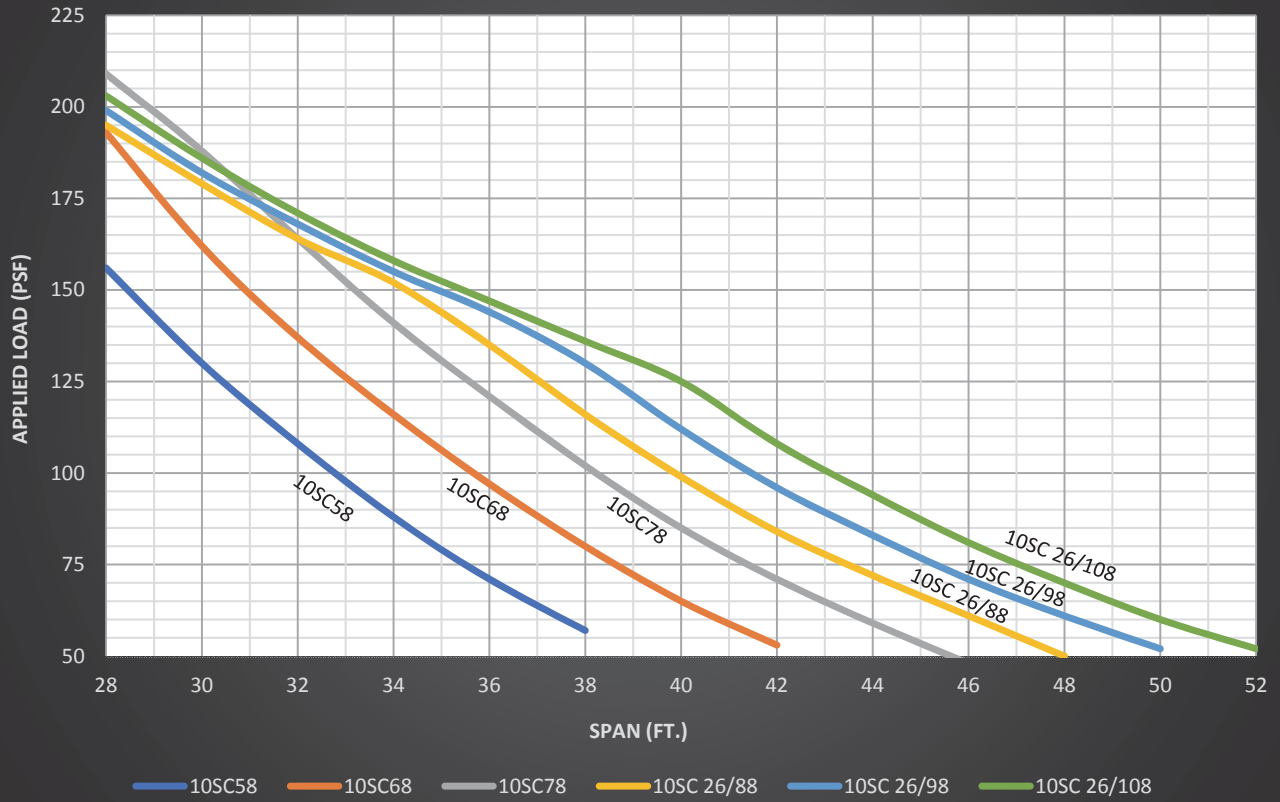

## 10" Composite Load Table

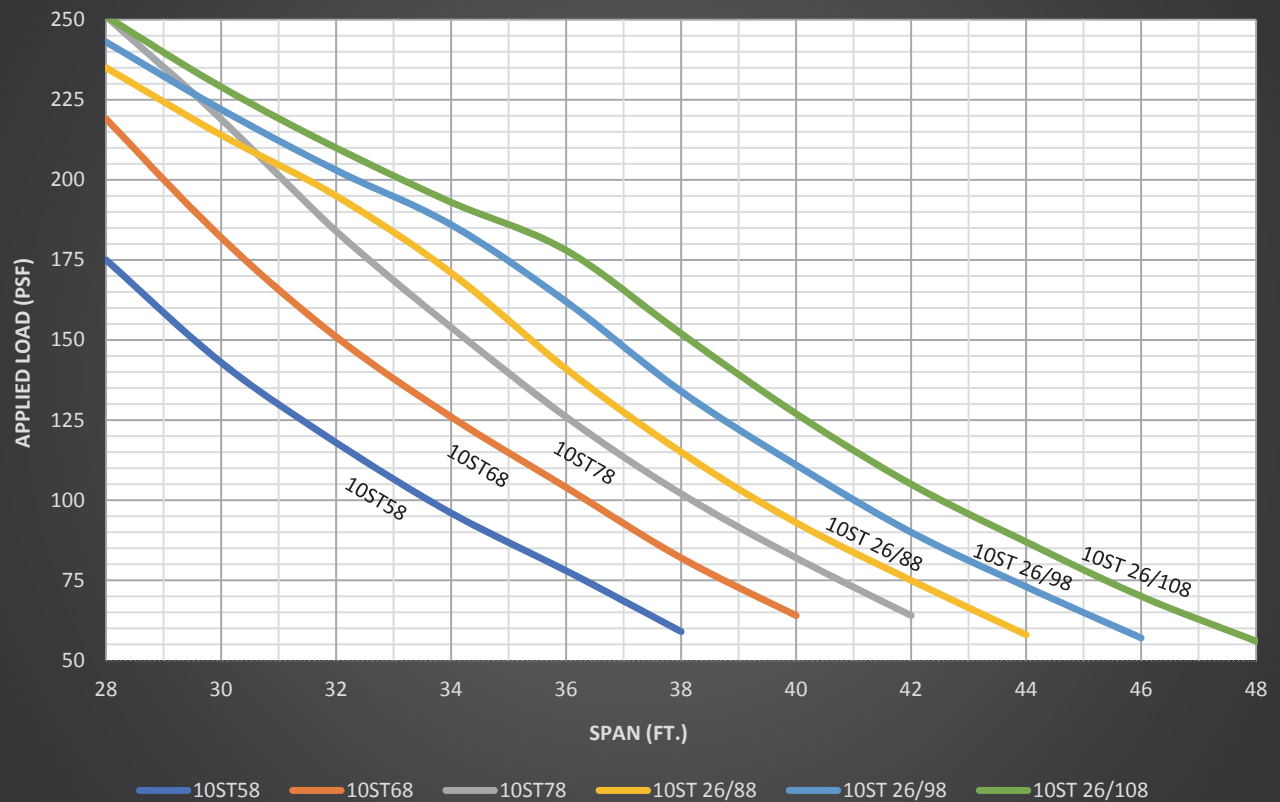

## 10" COREFLOOR FIGURES INDICATE SUPERIMPOSED LOADS

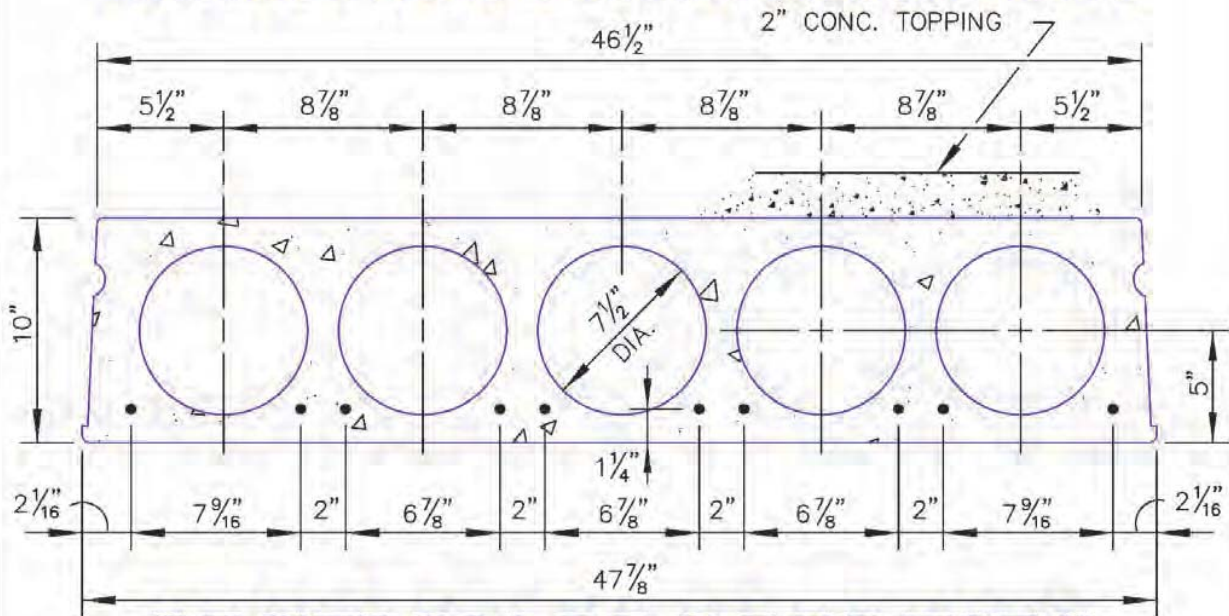

### SECTION PROPERTIES

**NON-COMPOSITE**  
 $A = 259 \text{ IN.}^2$        $I = 3223 \text{ IN.}^4$   
 $Y_b = 5.0 \text{ IN.}$        $WT = 67 \text{ PSF}$   
 $Y_t = 5.0 \text{ IN.}$

**COMPOSITE**  
 $A = 355 \text{ IN.}^2$        $I = 5348 \text{ IN.}^4$   
 $Y_b = 6.35 \text{ IN.}$        $WT = 91 \text{ PSF}$   
 $Y_t = 5.65 \text{ IN.}$

### SPAN IN FEET

STRAND	28'	30'	32'	34'	36'	38'	40'	42'	44'	46'	48'	50'	52'
10SC58	156	130	108	88	71	57							
10SC68	193	162	137	116	97	80	65	53					
10SC78	209	188	164	141	121	102	85	71	59	48			
10SC $\frac{26}{88}$	195	179	164	152	135	116	99	84	72	61	50		
10SC $\frac{26}{98}$	199	182	168	155	144	130	112	96	83	71	61	52	
10SC $\frac{26}{108}$	203	186	171	158	147	136	125	108	94	81	70	60	52
10ST58	175	143	118	96	78	59							
10ST68	219	182	151	126	104	82	64						
10ST78	251	219	184	154	126	102	82	64					
10ST $\frac{26}{88}$	235	214	195	171	141	115	93	75	58				
10ST $\frac{26}{98}$	243	222	203	186	162	134	111	90	73	57			
10ST $\frac{26}{108}$	251	229	210	193	178	152	127	105	87	70	56		

SUPERIMPOSED LOAD CAPACITY IN POUNDS PER SQUARE FOOT

\* IMMEDIATE & LONG TERM DEFLECTION MAY LIMIT APPLICATION

$f_{ci} = 3500 \text{ PSI} - 4500 \text{ PSI}$

$f_c = 6500 \text{ PSI}$

STRAND = 270 KSI L.R.

CONCRETE TOPPING = 4000 PSI

SC - UNTOPPED SECTION

ST - 2" COMPOSITE TOPPING

## 12" Non-Composite Load Table

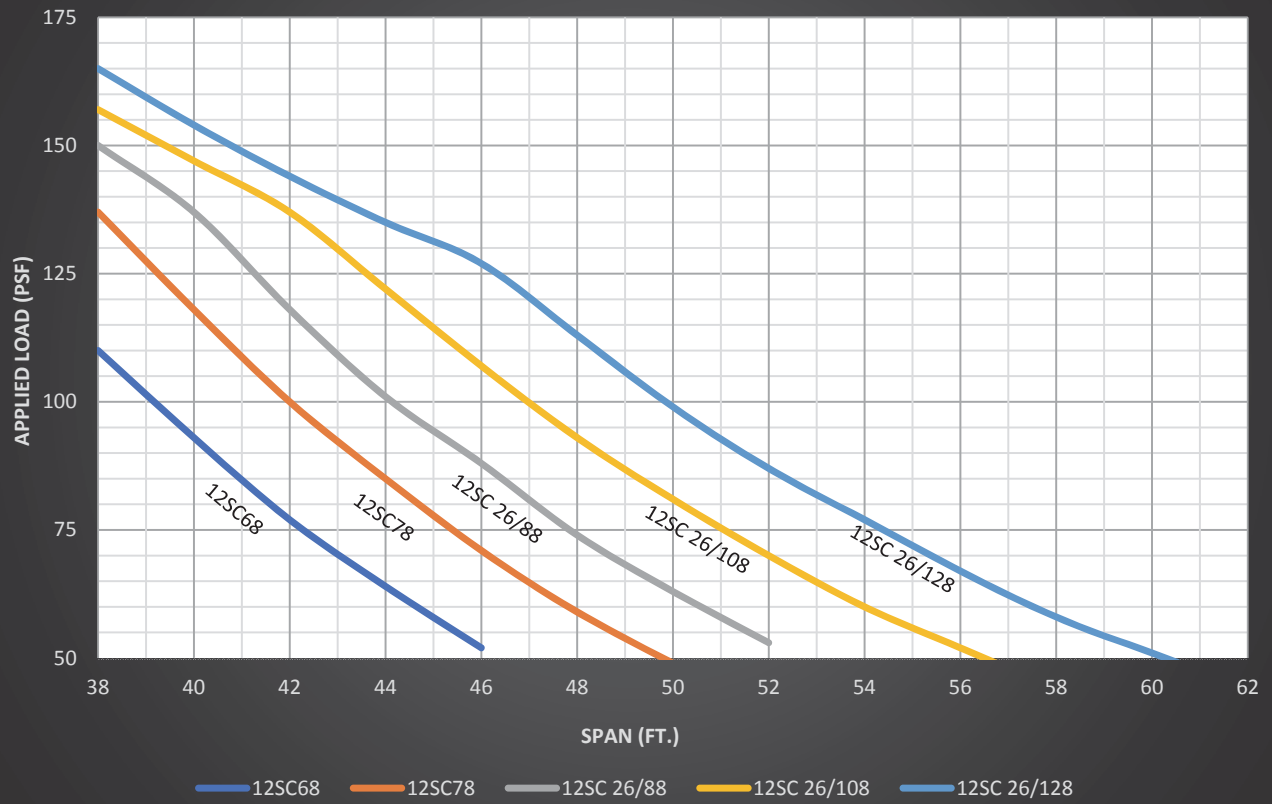

## 12" Composite Load Table

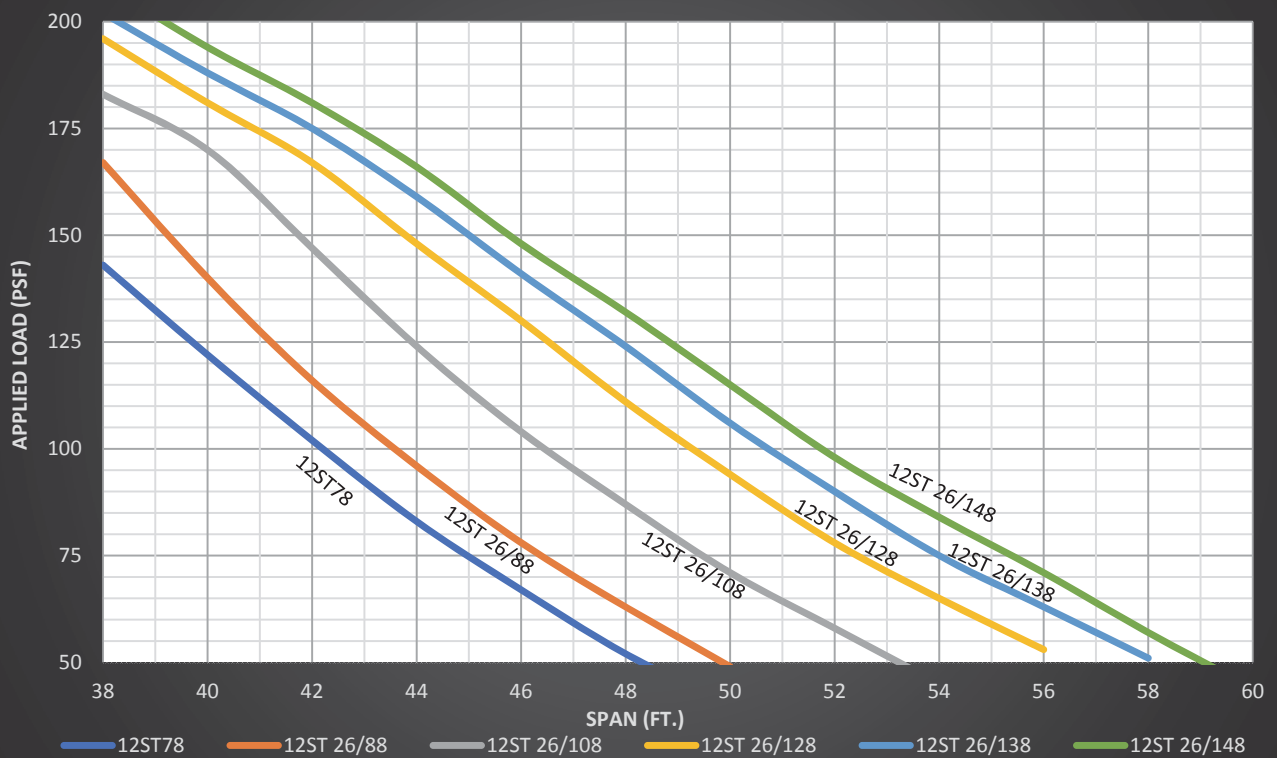

## 12" COREFLOOR FIGURES INDICATE SUPERIMPOSED LOADS

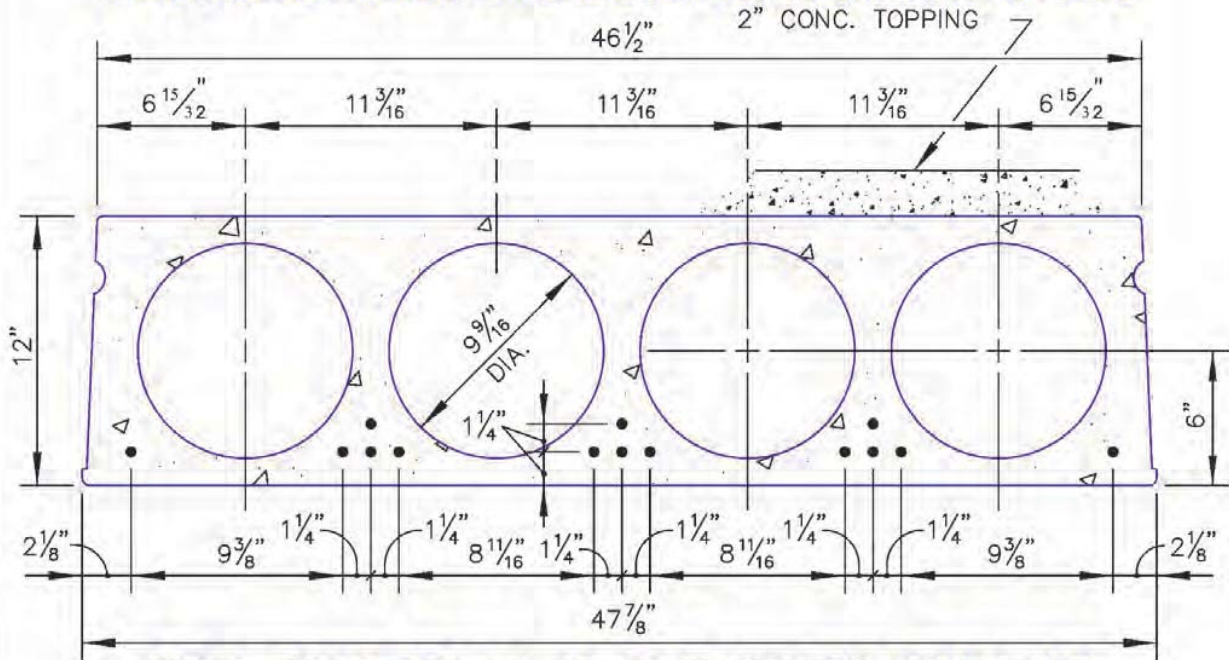

### SECTION PROPERTIES

NON-COMPOSITE		COMPOSITE	
A = 279 in. <sup>2</sup>	I = 5153 in. <sup>4</sup>	A = 375 in. <sup>2</sup>	I = 8084 in. <sup>4</sup>
Y <sub>B</sub> = 6.0 in.	WT = 73 PSF	Y <sub>B</sub> = 7.49 in.	WT = 98 PSF
Y <sub>T</sub> = 6.0 in.		Y <sub>T</sub> = 6.51 in.	

### SPAN IN FEET

STRAND	38'	40'	42'	44'	46'	48'	50'	52'	54'	56'	58'	60'	62'
12SC68	110	93	77	64	52								
12SC78	137	118	100	85	71	59	49						
12SC 26/88	150	137	118	101	88	74	63	53					
12SC 26/108	157	147	137	122	107	93	81	70	60	52	44		
12SC 26/128	165	154	144	135	127	113	99	87	77	67	58	51	44
12ST78	143	122	102	83	67	52							
12ST 26/88	167	140	116	96	78	63	49						
12ST 26/108	183	170	147	124	104	87	71	58	45				
12ST 26/128	196	181	167	148	130	111	94	78	65	53			
12ST 26/138	202	188	175	159	141	124	104	90	75	63	51		
12ST 26/148	209	194	181	166	148	132	115	98	84	71	57	44	

SUPERIMPOSED LOAD CAPACITY IN POUNDS PER SQUARE FOOT

\* IMMEDIATE & LONG TERM DEFLECTION MAY LIMIT APPLICATION  
 f<sub>ci</sub> = 3500 PSI-5500 PSI      CONCRETE TOPPING = 4000 PSI  
 f<sub>c</sub> = 6500 PSI      SC- UNTOPPED SECTION  
 STRAND = 270 KSI L.R.      ST- 2" COMPOSITE TOPPING

## 14" Non-Composite Load Table

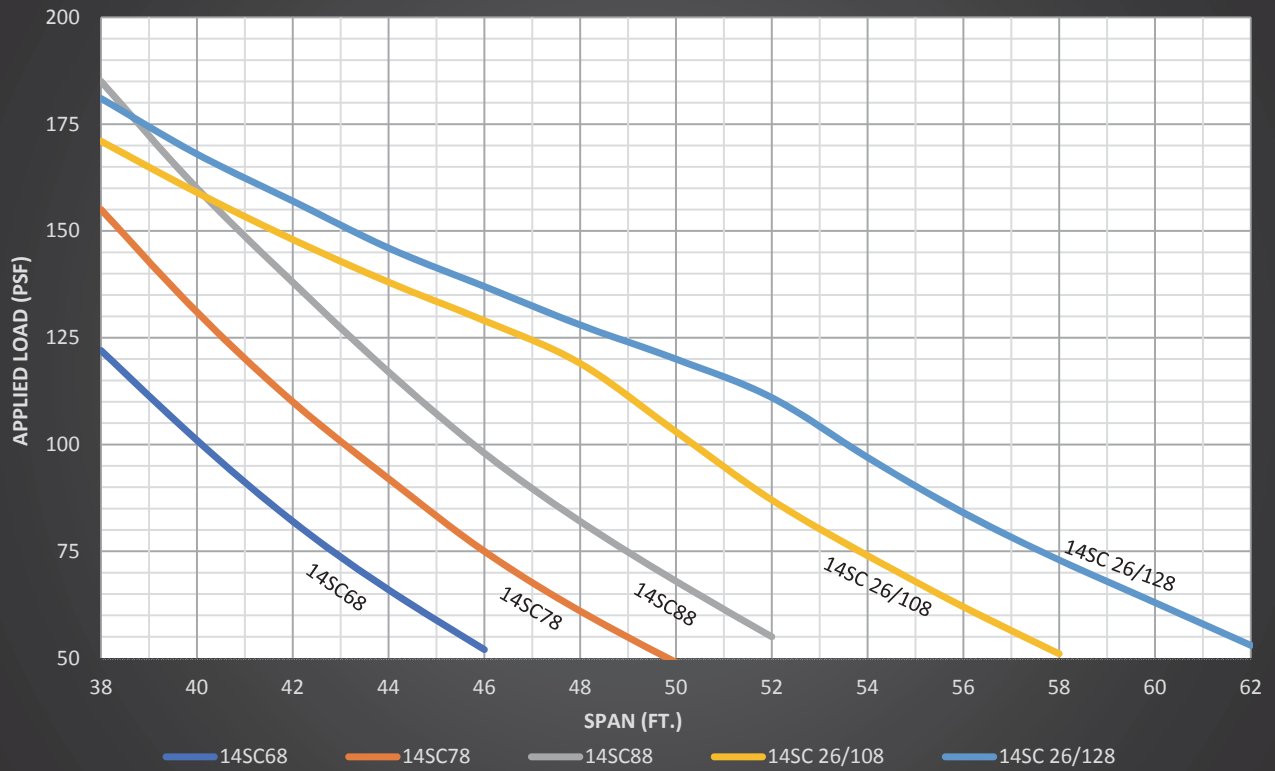

## 14" Composite Load Table

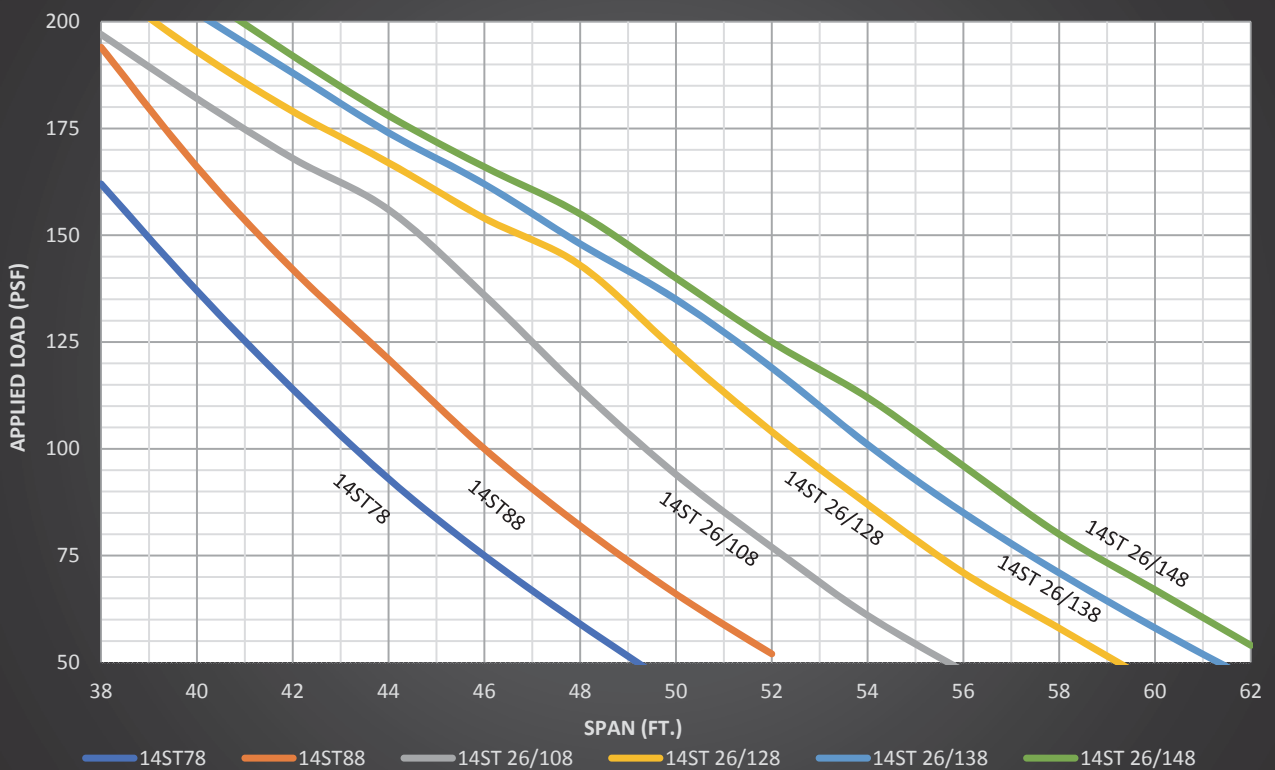

## 14" COREFLOOR FIGURES INDICATE SUPERIMPOSED LOADS

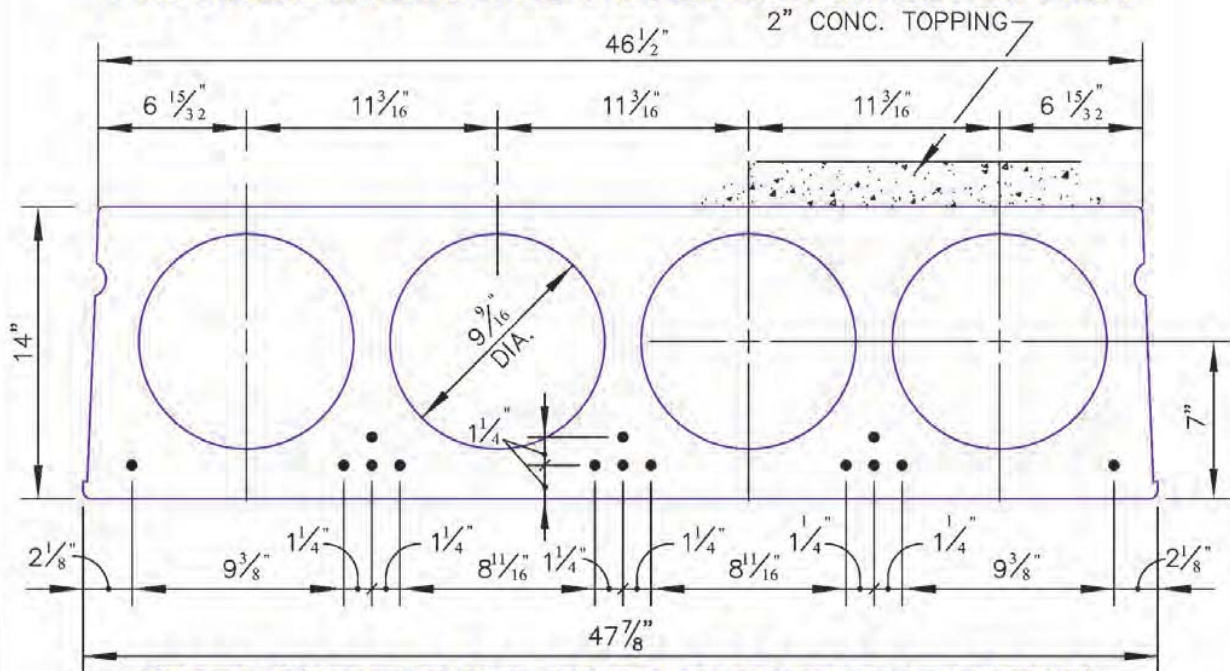

### SECTION PROPERTIES

#### NON-COMPOSITE

$A = 373 \text{ IN.}^2$        $I = 9231 \text{ IN.}^4$   
 $Y_B = 7.0 \text{ IN.}$        $WT = 98 \text{ PSF}$   
 $Y_T = 7.0 \text{ IN.}$

#### COMPOSITE

$A = 469 \text{ IN.}^2$        $I = 13266 \text{ IN.}^4$   
 $Y_B = 8.34 \text{ IN.}$        $WT = 123 \text{ PSF}$   
 $Y_T = 7.66 \text{ IN.}$

### SPAN IN FEET

STRAND	38'	40'	42'	44'	46'	48'	50'	52'	54'	56'	58'	60'	62'
14SC68	122	101	82	66	52								
14SC78	155	131	110	92	75	61	49						
14SC88	185	160	138	117	98	82	68	55					
14SC $26/108$	171	159	148	138	129	119	103	87					
14SC $26/128$	181	168	157	146	137	128	120	111	97	84			
14ST78	162	137	114	93	75	59	44						
14ST88	194	166	142	121	100	82	66	52					
14ST $26/108$	197	182	168	156	136	114	94	77					
14ST $26/128$	209	193	179	167	154	143	123	104	87	71			
14ST $26/138$		202	188	174	162	148	135	119	101	85	71	58	46
14ST $26/148$		207	192	178	166	155	140	125	112	96	80	67	54

SUPERIMPOSED LOAD CAPACITY IN POUNDS PER SQUARE FOOT

\* IMMEDIATE & LONG TERM DEFLECTION MAY LIMIT APPLICATION

$f_{ci} = 3500 \text{ PSI} - 4500 \text{ PSI}$

$f_c = 6500 \text{ PSI}$

STRAND = 270 KSI L.R.

CONCRETE TOPPING = 4000 PSI

SC- UNTOPPED SECTION

ST- 2" COMPOSITE TOPPING

# 6" COREFLOOR

## STRAND PATTERN

### 4 STRAND

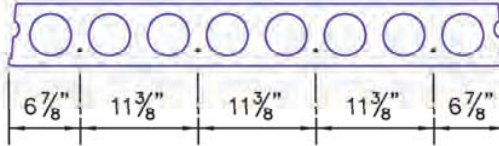

### 5 STRAND

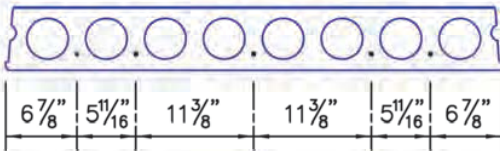

### 6 STRAND

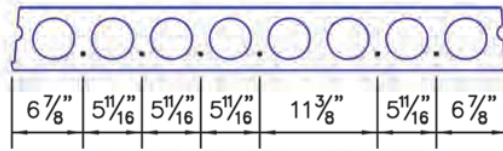

### 7 STRAND

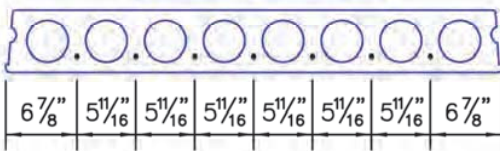

### 9 STRAND

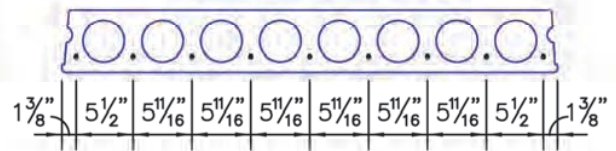

# 8" COREFLOOR

## STRAND PATTERN

### 4 STRAND

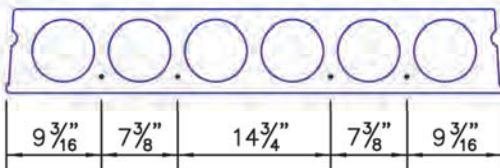

### 5 STRAND

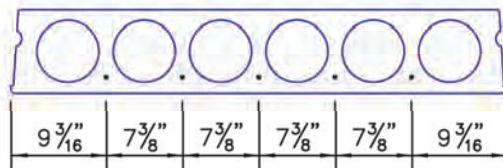

### 6 STRAND

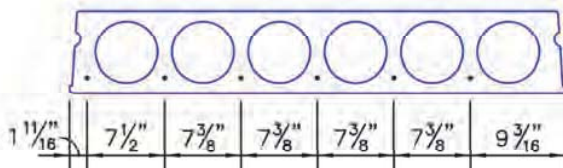

### 7 STRAND

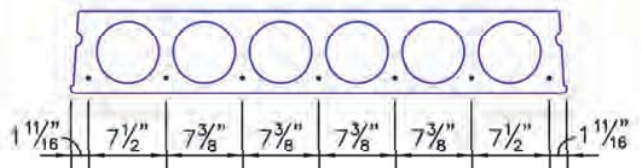



# 10" COREFLOOR STRAND PATTERN

## 5 STRAND

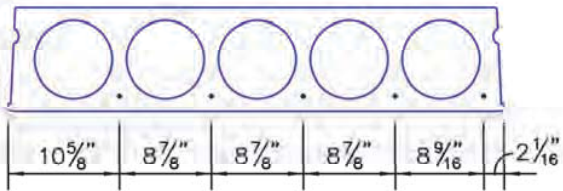

## 6 STRAND

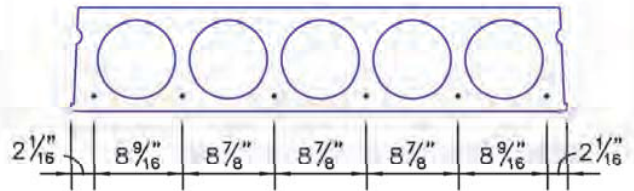

## 8 STRAND

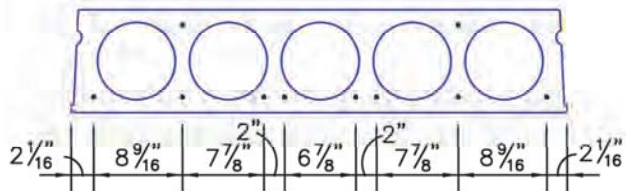

## 10 STRAND

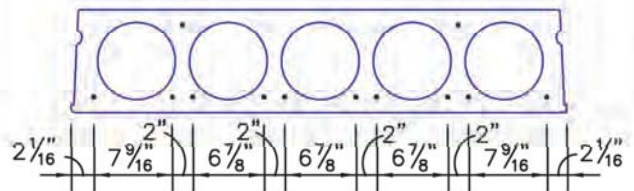

# 12" COREFLOOR STRAND PATTERN

## 5 STRAND

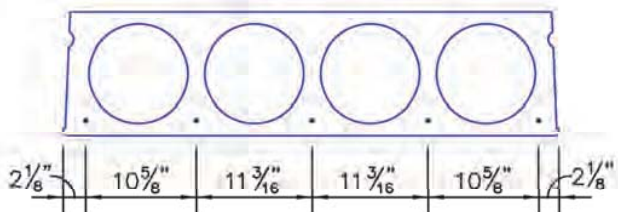

## 8 STRAND

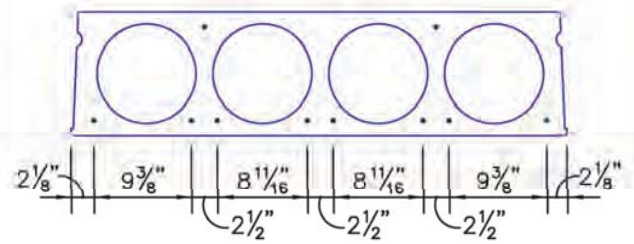

## 11 STRAND

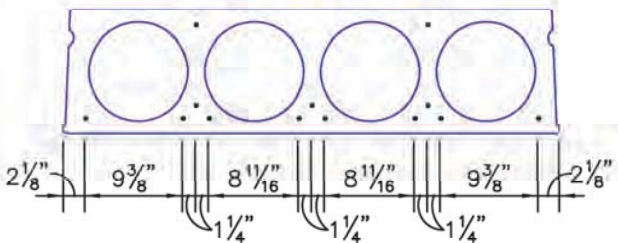

## 14 STRAND

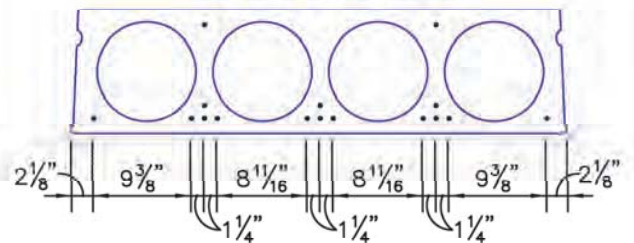

# COREFLOOR ON MASONRY

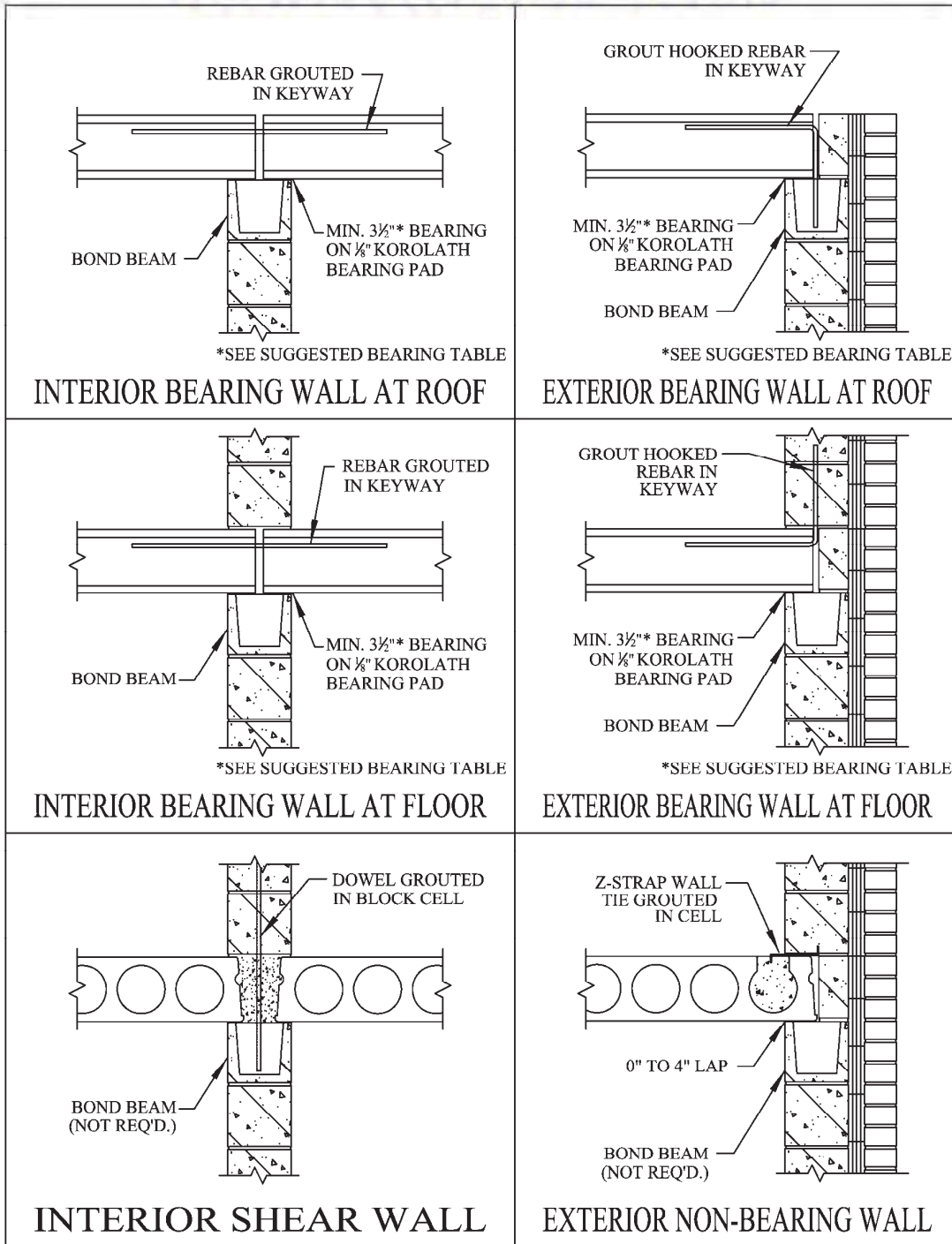

<b>Suggested Min. Bearing</b>								
<i>Span</i>								
<i>Bearing Surface</i>	20'	30'	35'	40'	45'	50'	55'	60'
Concrete/Masonry	3 1/2"	3 1/2"	3 1/2"	3 1/2"	3 1/2"	4"	4 1/4"	4 1/2"

*Note: Dimensions include 1/2" fabrication tolerance.*

# COREFLOOR ON CONCRETE

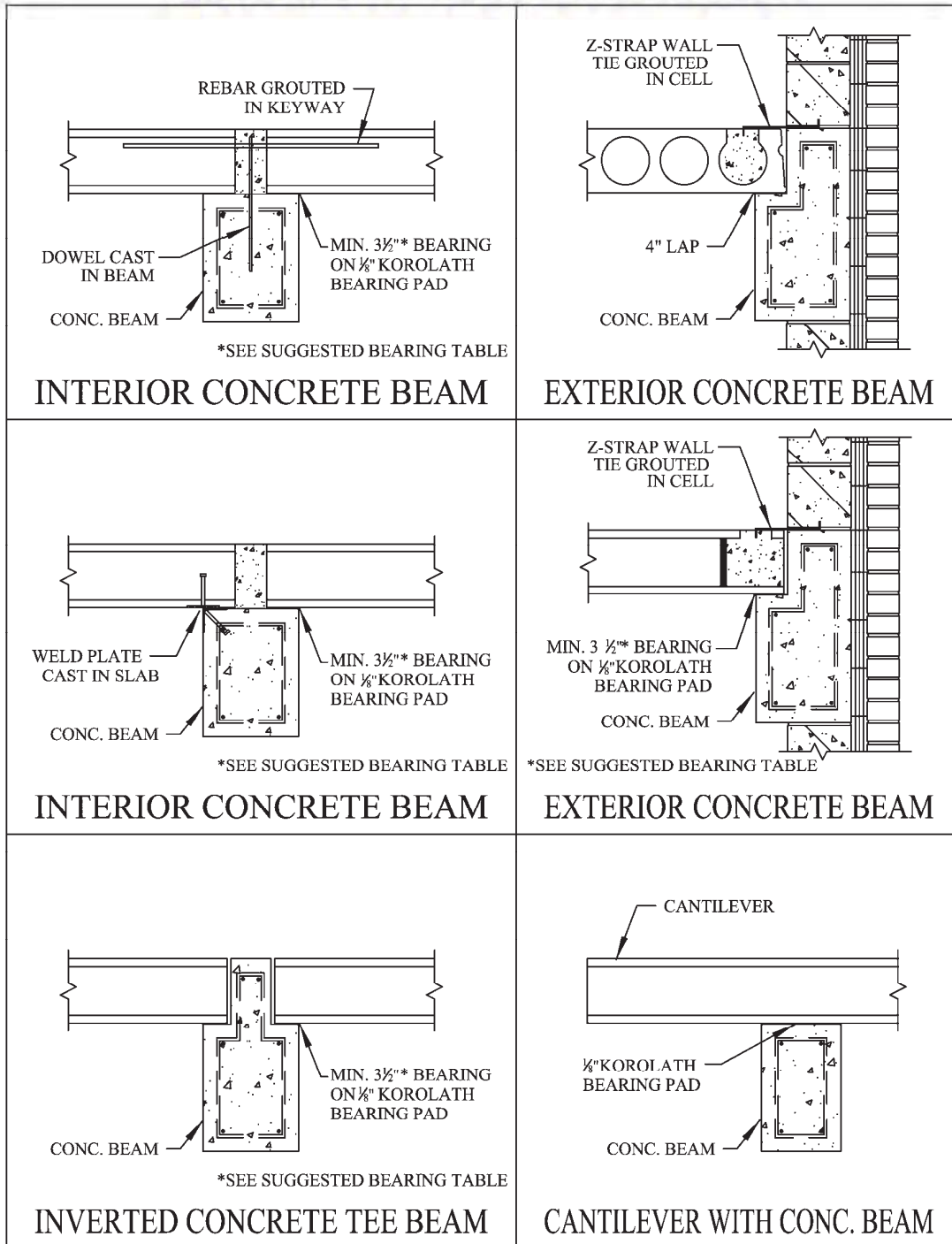

Suggested Min. Bearing								
Span								
Bearing Surface	20'	30'	35'	40'	45'	50'	55'	60'
Concrete/Masonry	3 1/2"	3 1/2"	3 1/2"	3 1/2"	3 1/2"	4"	4 1/4"	4 1/2"

*Note: Dimensions include 1/2" fabrication tolerance.*

# COREFLOOR ON STRUCTURAL STEEL

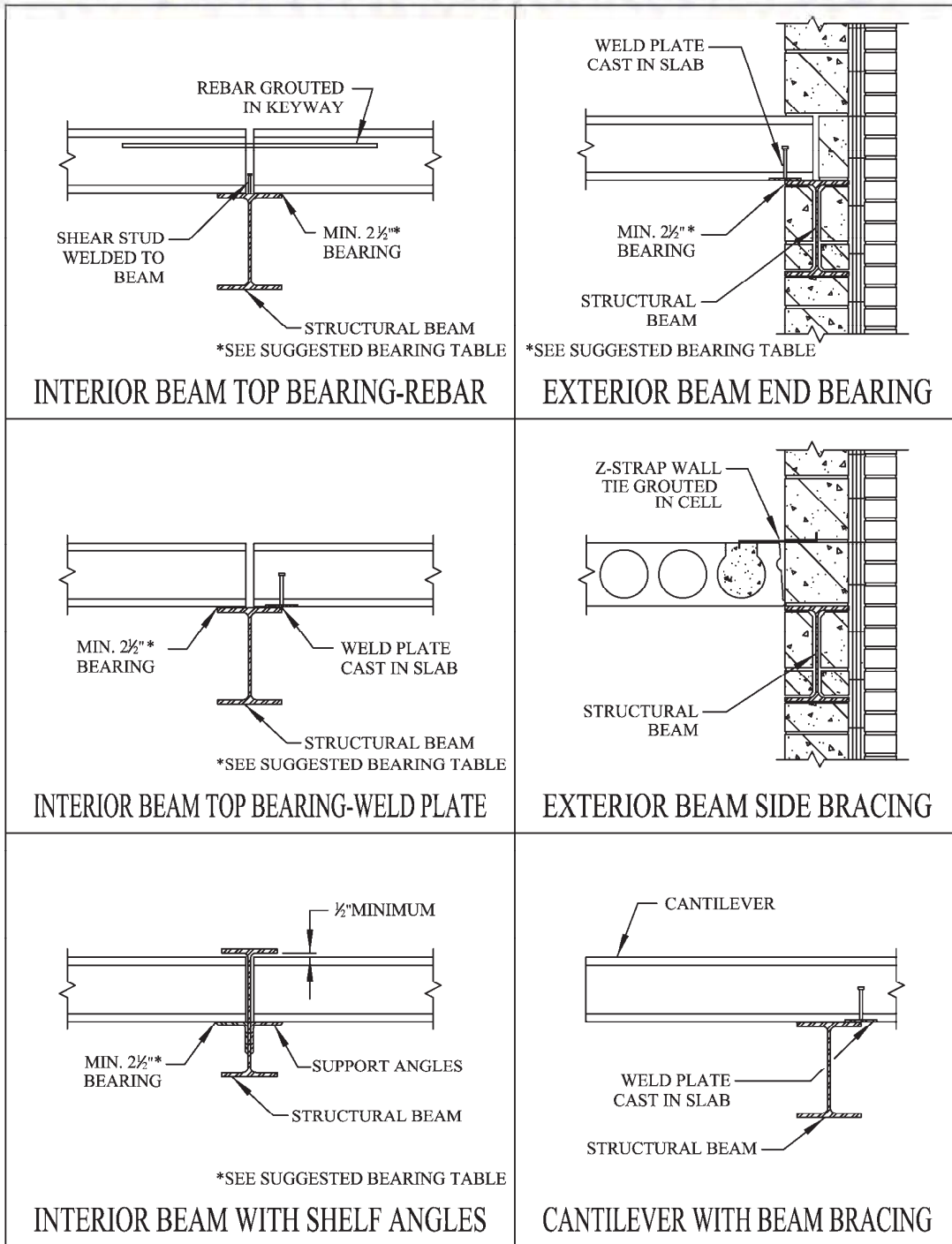

Suggested Min. Bearing								
Span								
Bearing Surface	20'	30'	35'	40'	45'	50'	55'	60'
Concrete/Masonry	2 1/2"	2 1/2"	3"	3 1/4"	3 1/2"	4"	4 1/4"	4 1/2"

Note: Dimensions include 1/2" fabrication tolerance.

## Estimated Camber

Camber is the upward deflection of a pre-stressed member and results from the prestressing force being eccentric from the center of gravity of the cross-section. Since both prestressing force and eccentricity are established by the required design load and span length, camber is a result of a design rather than a design parameter. Therefore, camber requirements should not be specified.

Camber will change with time due to concrete creep, prestress loss and other factors. Long term cambers are not predictable with any degree of accuracy and any calculations must be considered to be only estimates.

*Camber adjustment for 40° temperature difference between top and bottom surface*

	Span			
	25'	35'	45'	55'
6" Corefloor	0.32 in. +/-			
8" Corefloor	0.24 in. +/-	0.46 in. +/-		
10" Corefloor	0.19 in. +/-	0.37 in. +/-	0.61 in. +/-	
12" Corefloor	0.16 in. +/-	0.32 in. +/-	0.51 in. +/-	0.76 in. +/-
14" Corefloor	0.19 in. +/-	0.38 in. +/-	0.62 in. +/-	0.93 in. +/-

*The hollowcore will bow toward the warmer surface*

Erection Camber										
Strand	Span									
	15'	20'	25'	30'	35'	40'	45'	50'	55'	60'
6SC56	0.20 in	0.15 in								
6SC57	0.30 in	0.35 in	0.10 in							
6SC58	0.50 in	0.60 in	0.55 in							
6SC78	0.75 in	1.00 in	1.20 in	1.00 in						
8SC47		0.20 in	0.15 in							
8SC48		0.35 in	0.40 in	0.20 in						
8SC58		0.50 in	0.60 in	0.50 in						
8SC68			0.80 in	0.85 in	0.60 in					
8SC78			1.00 in	1.20 in	1.00 in	0.55 in				
10SC58			0.45 in	0.45 in	0.30 in					
10SC68			0.60 in	0.70 in	0.60 in					
10SC78			0.80 in	0.90 in	0.90 in	0.70 in				
10SC26 / 88				0.90 in	0.85 in	0.60 in				
10SC26 / 108				1.30 in	1.50 in	1.40 in	1.10 in			
12SC68				0.60 in	0.65 in	0.50 in				
12SC26 / 88					0.85 in	0.75 in	0.40 in			
12SC26 / 108					1.30 in	1.40 in	1.20 in	0.85 in	0.10 in	
12SC26 / 128					1.80 in	1.90 in	2.00 in	1.70 in	1.20 in	
12SC26 / 148					2.00 in	2.30 in	2.40 in	2.40 in	2.00 in	1.20 in
14SC78						0.40 in	0.15 in			
14SC88						0.65 in	0.45 in	0.00 in		
14SC26 / 108						0.80 in	0.65 in	0.30 in		
14SC26 / 128						1.20 in	1.20 in	0.90 in	0.40 in	
14SC26 / 138						1.40 in	1.40 in	1.20 in	0.75 in	-0.05 in
14SC26 / 148						1.60 in	1.60 in	1.50 in	1.10 in	0.35 in

## EXPLANATION OF LOAD TABLES

1. Strand designations:

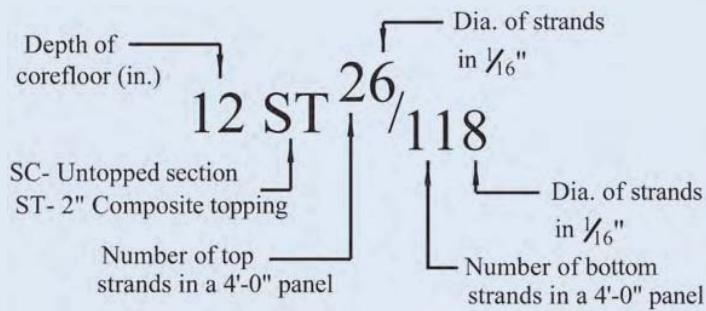

2. Spans are clear spans
3. The loads indicated are superimposed. The weight of the corefloor or corefloor and composite topping are not to be subtracted.

## OPENINGS

The extrusion process precludes forming openings during the manufacturing process. Large openings, one full slab or more in width, are accomplished with steel headers appropriately supported by adjacent slabs or otherwise. Small openings, 6" and less can be field drilled into and through cores as required by mechanical, electrical or other trades.

Intermediate openings, that require the cutting of prestressing strands, must be discussed with StresCore Inc. for the least invasive layout while providing an efficient and economical solution.

## SPECIAL SLAB WIDTHS

The extrusion machine produces a standard 48" wide slab. Narrower slabs must be sawed to width by StresCore Inc. For greatest economy lay out decks for maximum use of full width slabs.

## CANTILEVERS

Unsupported side projections of COREFLOOR without top steel should be limited to 12". Cantilever applications are readily accomplished with special placement of the prestressing strands in the hollowcore.

## STRUCTURAL BEARING SURFACES

Smooth and level bearing surfaces must be provided by others for the COREFLOOR erector. The minimum recommended bearing is  $3\frac{1}{2}$ " on masonry and concrete, and  $2\frac{1}{2}$ " on structural steel. See typical details elsewhere in the brochure for additional bearing guidance.

## NON-LOAD BEARING PARTITIONS

In order to make allowances for possible temperature movement, non-load bearing partitions should not be connected rigidly to the corefloor.

## STRUCTURAL CONNECTIONS

Typical details on adjacent pages of this brochure demonstrate the simplicity of structural connections. The type, number, and location of the structural connectors should be selected to suit the requirements of the specific structure. It is recommended that only those connections actually needed in order to assure the structural integrity of the building be specified so that the true economy of the COREFLOOR system is realized.

## BEARING STRIPS

Korolath is an engineered multipolymer plastic with a compressive strength of 8,000 to 9,000 psi. It will not rust, rot or leach. ( $\frac{1}{8}$ " Korolath is recommended)

## GROUT KEYS

All grout keys should be filled with a 1:3 cement sand grout to assure distribution of loads to adjacent slabs. In order to prevent cracking of the topping, grout in floor system grout keys should be allowed to cure before the topping is placed. Grout leakage should be removed before it hardens on finished ceiling areas.

## NON-STRUCTURAL CONNECTIONS AND HANGERS

Since screw inserts, studs, hangers, etc. cannot be embedded during the manufacturing process, designers should specify the placement of connections in the grout keys or cores as a job site operation.

## CAULKING

Longitudinal joints between slabs should be caulked, by others, with a uniform bead in the joints when the under surface of the slab is to be finished construction. Use non-staining, non-shrink caulk.

## PAINTING AND FINISHING

The underside of the corefloor has a smooth steel form finish suitable, without further treatment, for textured paint applications or acoustic plaster. Care must be exercised to assure that the paint will cover normal pin holes and the concrete finish.

## CARPETING AND FLOORING

A minimum 2" topping is recommended however thicker sections should be considered under various applications. However, an underlayment is suggested when padding and carpeting are to be directly applied to COREFLOOR without a 2" topping. Some slight variations in camber are to be expected, especially on longer spans. A Gypcrete coat of  $\frac{1}{2}$ " gypsum cement can be applied to provide a smooth surface.

# Preparation for Topping

ACI standards provide guidance on the preparation and treatment of the concrete topping. This guidance helps ensure that the topping will have a good bond with the hollowcore and concrete delaminations will not occur. Since the concrete topping is often designed as composite with the hollowcore, a well bonded topping is required to meet design parameters. A poorly bonded topping may result in a reduction in the structural capacity of the hollowcore and topping or have a reduction in the long term durability of the topping.

Recommendations for the topping include:

1. Precast must be thoroughly cleaned of all debris that would prevent bonding. This includes sawdust, trash, dirt, masonry material, etc.
2. A suitable bonding agent or bonding procedure is recommended. This may include treatment of the slab surface with a cement slurry mixture, an epoxy bonding agent or applying a broom finish at the plant to roughen the top surface of the hollowcore pre-cast slabs. It is imperative that the bonding agent does not reach the initial set prior to placement. This may act as a bond breaker if allowed to set prior to topping placement.
3. Moisten the hollowcore surface prior to placement of the topping. Moistening should follow manufacturers guidance if a bonding agent is utilized. The surface should be fully saturated prior to the topping placement, however all standing water should be removed.
4. Review topping details in relation to camber. Consider plan details to address camber and adjust concrete quantities for longer span slabs and slabs with large camber. See Figure 4.

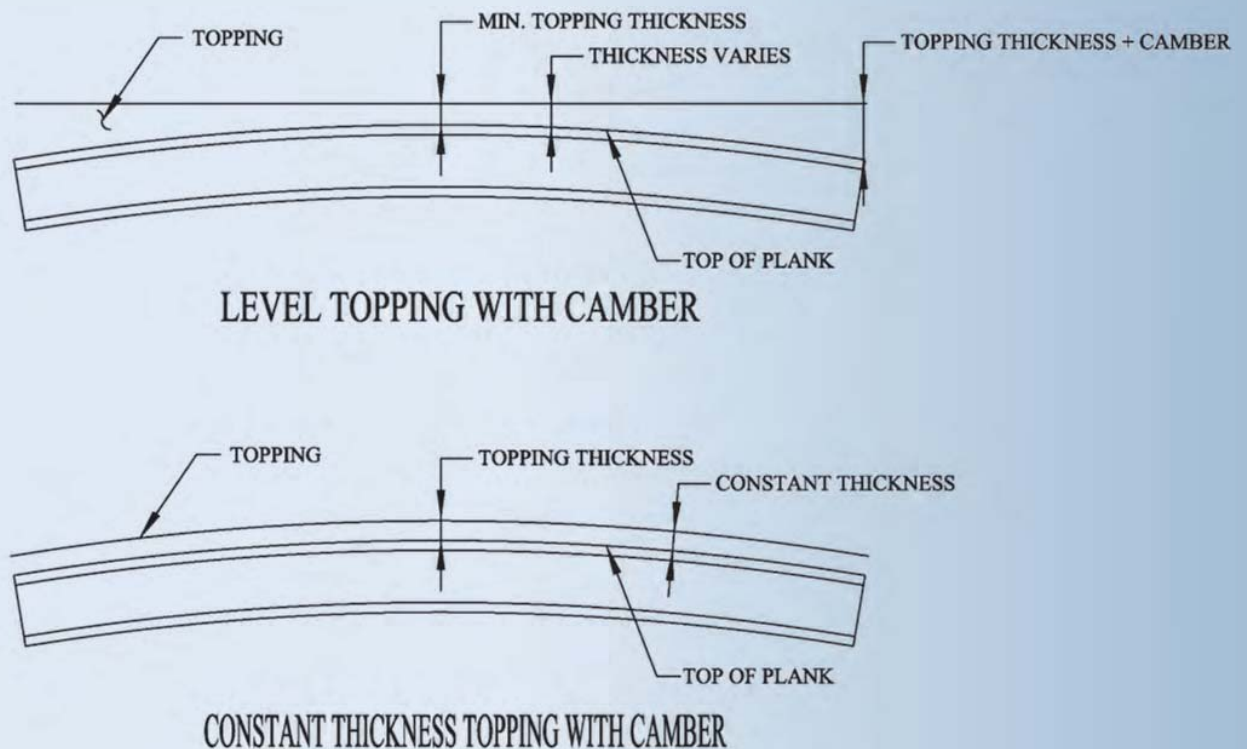
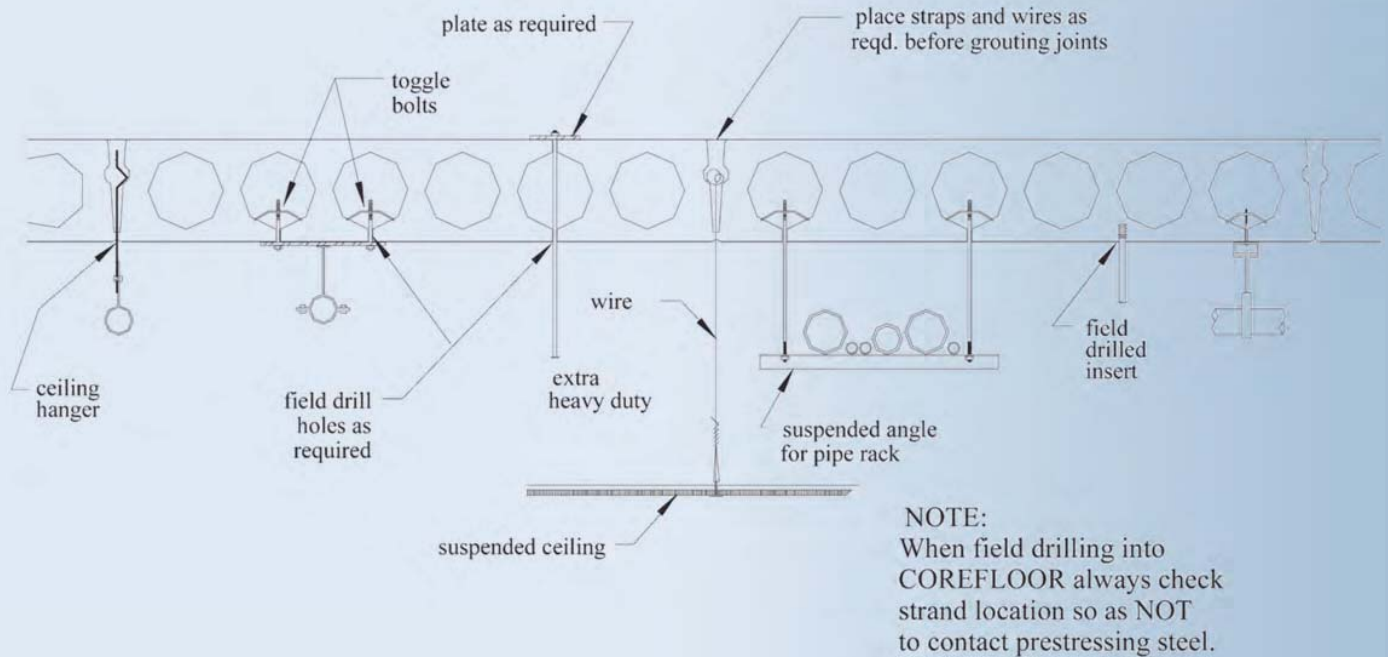
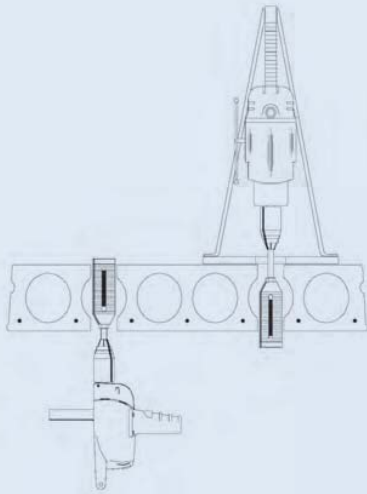

FIGURE 4

## Hanging Other Construction From Corefloor



## Field Cutting Openings Through Corefloor



1. For ease of field cutting openings try to go through hollow cores.
2. Do NOT strike or cut any prestressing strands without permission of StresCore, Inc. and the Architect/Engineer.
3. There will be some spalling at the exit point of the tool through the COREFLOOR deck.
4. When field cutting openings 1" to 6" diameter a core drill or a cutoff saw can be used.

## Large Openings - Structural Hanger Details

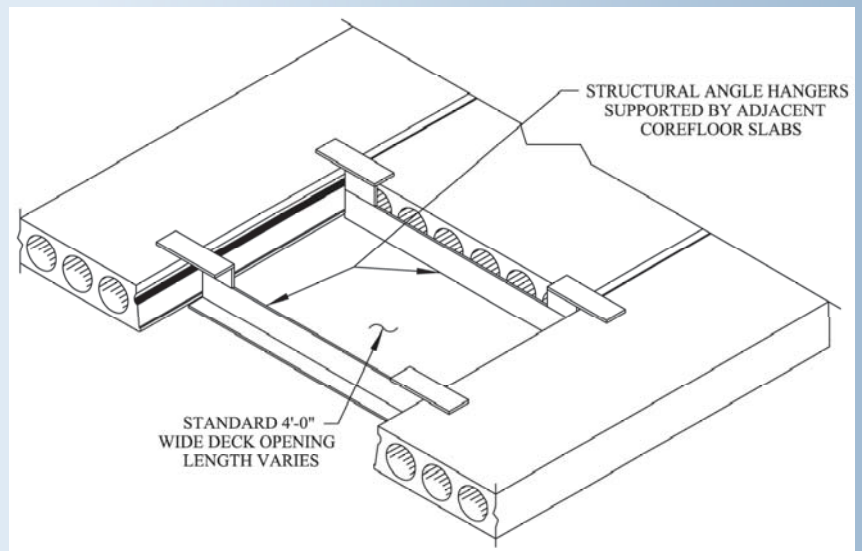

1. For large openings, a steel hanger can be utilized.
2. The standard hanger opening is 4' (preferred), however various opening widths can be provided. Limit openings to 8' maximum with a hanger.
3. Place openings such that the hanger can bear on a full 4' plank on either side.



# Specifications

## GENERAL:

The work under this section shall be furnished and/or furnished and erected in conformity with the general conditions, special conditions, including modifications and governing contract documents.

## WORK INCLUDED:

1. Furnish, deliver and erect all prestressed floor and roof slabs.
2. If purchaser elects to perform own erection, StresCore, Inc. reserves the right to direct and inspect the erection and grouting.
3. Furnish and install weld plates, headers, as required per shop drawings.
4. Grout the joints with a 3:1 sand/cement mix design. It shall be done by the erector in a workman-like manner.
5. Submit shop drawings to the Architect for approval, showing setting plan, reinforcing details, etc.
6. The furnishing of openings greater than 6" in diameter, as shown on plans.

## WORK NOT INCLUDED:

1. Caulking joints in finished ceiling area as required.
2. Concrete topping
3. Concrete for lintels at wall connections.
4. Forming, shoring and miscellaneous supports.
5. Hangers for piping, conduit, etc.
6. Mechanical openings less than 6" in diameter.

## MATERIALS AND FABRICATION:

Floor and roof slabs shall be COREFLOOR as manufactured by StresCore Inc., of South Bend, IN.

## MATERIALS USED IN THE MANUFACTURE OF COREFLOOR SHALL CONFORM TO THE FOLLOWING SPECIFICATIONS:

1. All concrete materials shall be clean and properly graded. The concrete shall have a minimum compressive strength of 3,500 PSI at release of prestress strands and 6,500 PSI at 28 days.
2. Prestressing strands shall be uncoated, 7 wire low relaxation conforming to A.S.T.M. C-416.
3. Portland Cement A.S.T.M. C-150.
4. Concrete Aggregates A.S.T.M. C-33.
5. Curing of slabs shall be by a method suitable to obtain uniformity of color and strength. The strength shall be as specified under item (1).
6. Slabs shall be 48" x 6", with eight 4" dia. cores, 48" x 8", with six 6" dia. cores, 48" x 10", with five 7 1/2" dia. Cores, 48" x 12", with four 9 9/16" dia. cores or 48" x 14", with four 9 9/16" dia. cores in each slab and prestressed to sustain the superimposed loads as indicated on the drawings. In general the design of the slabs shall conform to ACI 318-14.

## ERECTION AND INSTALLATION:

1. Erection shall be carried out by experienced workman under competent supervision.
2. Bearing surface shall be prepared by others true to a level line. The minimum recommended bearing is 3  $\frac{1}{2}$ " on masonry or concrete, and 2  $\frac{1}{2}$ " on structural steel.
3. Installation of the slabs shall be made by leveling the floor and roof units in a workmanlike manner, keeping the units tight and at right angles to the bearing walls.
4.  $\frac{1}{2}$ " Ethafoam rope shall be placed in the bottom of the grout joint. The rope shall be placed securely so as not to permit grout to seep through the joint.
5. Slabs shall be grouted with a 1:3 cement-sand mix with proper care taken to see that the joints are properly filled. For estimating, the typical grout requirements are: 1 cubic yard per 2500 square feet.
6. Welding shall be done by experienced welders to fulfill the details shown on the drawings.

## TOLERANCES:

1. Length  $\pm \frac{1}{2}$ "
2. Cross section dimensions  $\pm \frac{1}{4}$ "
3. Weld plates and inserts  $\pm 1$ "
4. Openings  $\pm 1 \frac{1}{2}$ "
5. Squareness  $\pm \frac{1}{2}$ "
6. Differential camber of units of like design less than  $\frac{1}{4}$ " per 10'-0", but not greater than  $\frac{1}{2}$ ".
7. Finish: Normal plant run finish. Small surface holes caused by air bubbles, minor chips and spalls will be tolerated.



# Notes

# **StresCore Inc.**

24445 State Road 23

South Bend, IN 46614

Office: (574)233-1117

Fax: (574)288-0050

Email: [sales@strescore.com](mailto:sales@strescore.com)

[www.strescore.com](http://www.strescore.com)

